



ACTIW LOADPLATE[®]

CASE STUDY 2013
/STEEL INDUSTRY

Actiw LoadPlate is a fast and proven, one shot loading solution for regular, non-modified cargo spaces. Stop losing money. Get payback on loading with LoadPlate.

LOADING DIFFICULT CARGO INTO STANDARD CONTAINERS

Actiw offers a unique automatic loading and unloading solution for standard cargo space. In the steel industry, the handled goods are often bulky and heavy, resulting in difficult containerization. By traditional methods, standard dry containers or trailers must often be replaced by expensive special containers. In addition, there is a high risk for both product damage and safety. The purpose of this case study is to explain how Actiw LoadPlate can resolve these issues and demonstrate the real, monetary business benefits it generates.

INTRODUCTION

The steel industry is global. Thus, the steel manufacturers often operate globally and orchestrate the distribution of large volumes of special cargo. As the distribution is widespread, owning a fleet of special containers is usually not a possibility, leaving leasing of the required containers as the only viable option. This has traditionally limited the possibility to automate loading.

A general misconception regarding automatic truck and container loading and unloading is that it always requires combined systems: one system in the trailer or container with fixed installations for both dispatching and receiving ends, or a special base frame structure under the cargo to accommodate the structures of the loading and unloading equipment. Actiw's LoadPlate proves all of this false by offering a system capable of automatic loading and unloading without any alterations needed in the standard cargo space, working on standard platforms with standard equipment.

These features result in major freight cost savings without hefty investments in an own fleet of containers or expensive special frames and compatible systems at the dispatching and receiving ends. Furthermore, LoadPlate significantly reduces the risk of product damages and accidents.

READ FURTHER, IF YOU WISH TO:

- understand what problems steel manufacturers around the world are facing in loading and unloading their special cargo
- figure out why many companies have chosen Actiw and whether Actiw's LoadPlate solution might benefit your business
- learn what kinds of tangible business benefits steel manufacturers have been able to gain by automating their container loading

LOADING HEAVY AND BULKY ITEMS – WHAT IS THE PAIN?

“It is becoming harder and harder to find open top or flatrack containers, not to mention the cost compared to regular dry containers”, a logistics manager at a major steel corporation explains the problems with special containers.

Steel products, no matter how sophisticated in nature, are usually shipped as long and heavy bars, rods, pipes and wire. Thus, the moving and especially the loading of these products is a rigorous task. A large part of the products can, by traditional means, only be loaded from the top into open top containers or from the side onto flatracks, while only a small part can be loaded through the single door of dry containers.

Many companies find themselves in a situation where they have to find a solution for loading and unloading dry containers. Besides the issue with availability of suitable containers, companies are struggling with capacity issues. Loading special cargo is time consuming and many times off-site containerization is the only possible, yet expensive, option to handle growing volumes. In addition to efficiency and monetary gains, improving health and

safety is a very strong driving force when rethinking logistics operations.

As the products are often shipped to customers and distributors around the world, most automated loading systems are out of the question. It is not possible to use your own fleet of altered containers and compatible systems at both sending and receiving ends when lacking full control of the entire logistics chain.

Actiw LoadPlate offers a proven solution for these issues. It loads difficult cargo fast and safe into standard containers, while saving a significant amount of money in the process.



THE ACTIW LOADPLATE – HOW DOES IT WORK?

Actiw LoadPlate is a one shot loading solution for regular, non-modified cargo space such as sea containers, trucks and trailers from 20 to 45 feet. LoadPlate is especially suitable for loading difficult cargo that is hard to containerize, is easily damaged or usually requires special shipping units such as open top or flatrack containers. The unloading can be done in one pull, working on standard platforms with standard equipment, when the cargo is prepared for unloading with Actiw LoadStrip, sling or other type of unloading preparation.

THE SYSTEM IS COMPRISED OF FIVE KEY ELEMENTS:

- **Loading Plate** – The loading plate is made out of extremely durable plastic, enduring 3 000 – 4 000 loads before replacement. The plate slides into the cargo space with the load and is then pulled out from underneath.
 - **Legs** – LoadPlate stands on two sets of legs. Both ends are height adjustable to cater standard trailer heights. The rear legs are adjustable also in horizontal direction, enabling automatic and accurate alignment with the cargo space.
 - **Gate** – The gate has several functions. It ensures that the cargo moves smoothly into the cargo space by supporting the cargo with side rollers. The gate supports the stopper plate, which moves up and down, holding the cargo in place when the loading plate is pulled out from beneath the cargo. The stopper plate also enables adjustment of the load to ensure that the doors can be shut freely.
 - **Container Connector Clamps** – The container connector clamps ensure that the container or trailer holds still during the loading process.
 - **Gear Motor** – LoadPlate works with an electric and hydraulic motor. The motors power all movement of the LoadPlate: loading plate, leg adjustments, the container connector clamps and the gate.
 - **Control System** – The sophisticated Programmable Logic Controller (PLC) based control system orchestrates all the movements, ensuring safe and easy usage of the system by a push of a button. The PLC can also be integrated into other software systems.
- There are different configurations of and accessories to LoadPlate, ensuring the optimal system for different loading requirements:
- **LoadPlate** – LoadPlate is ideal for loading all types of standard containers (20', 40' and 45') and varying trailer & truck lengths up to 13,6 meters. It is designed to load one container at a time. LoadPlate configurations vary from towable equipment to fixed installations, and from sophisticated PLC controlled operations to manually operated ones.
 - **LoadPlate Multi** – LoadPlate Multi fits environments with heavy container traffic, where container handling is done in different sequence from the load forming and loading operations. LoadPlate Multi enables effective, scheduled process cycles for heavy duty container handling devices and for the load forming functions. The containers are positioned side by side on supports and LoadPlate is moved on rails from one to another in turns.
 - **Unloading Table** – Generally, no special equipment is required at the receiving end for unloading the goods. In special cases, however, Actiw Unloading Table is perfect for quick unloading from standard cargo space when the cargo is prepared for unloading with Actiw LoadStrip, sling or other type of unloading preparation.
 - **LoadTransfer** – LoadTransfer is perfect for situations where containers need to be moved a couple of meters into the building or partially inside the dock opening for indoor loading.
 - **LoadStrip** – This clever accessory enables the unloading of cargo loaded by LoadPlate. It allows quick unloading from standard cargo space with standard trailer dock doors and platforms. Loadstrips are placed on LoadPlate's loading plate under the cargo. The unloading can be carried out with forklifts, terminal tractors, LoadPlate or Unloading Table by pulling out the cargo in one pull. Loadstrips are inexpensive, durable, reusable and recyclable.

“ONE SHOT IN, ONE PULL OUT!”

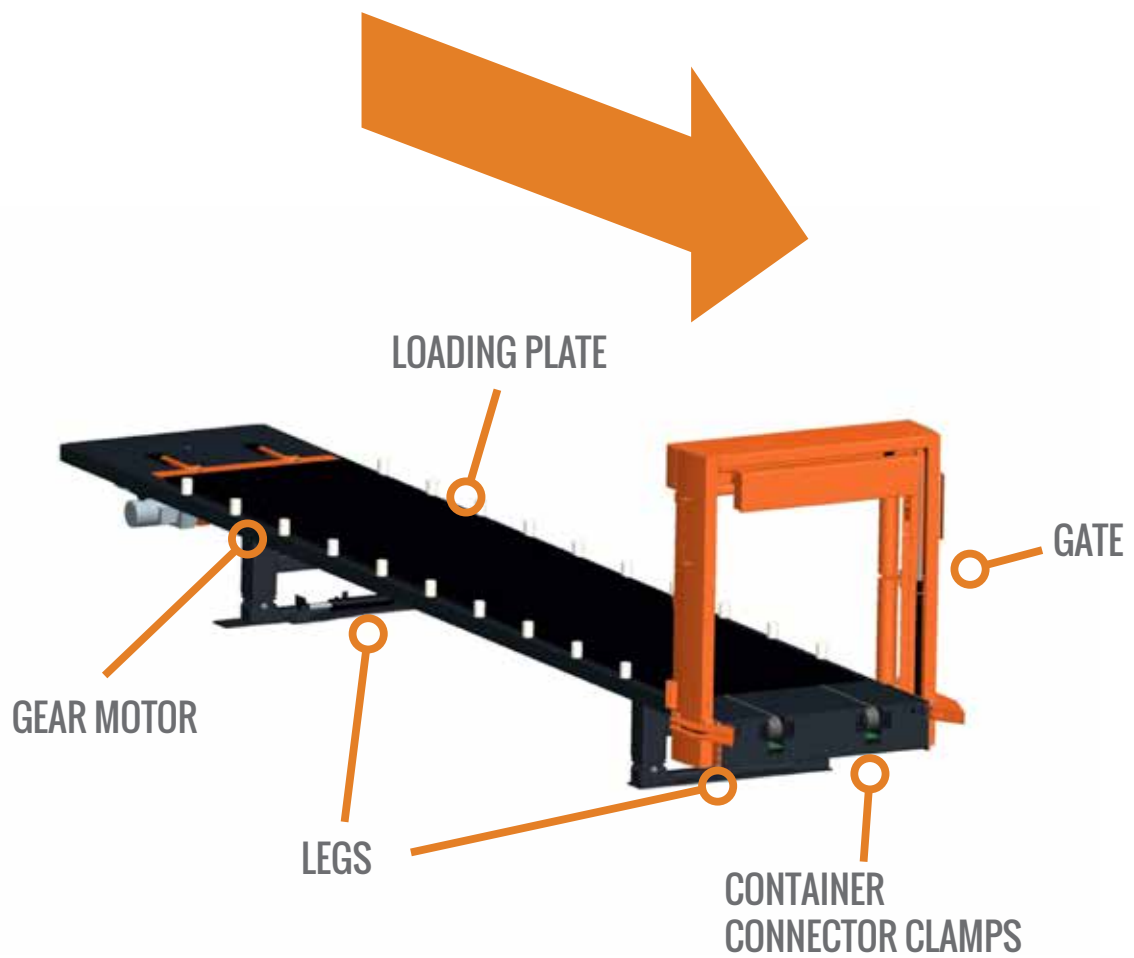

AUTOMATED LOADING & UNLOADING – WHAT OPTIONS ARE THERE?

Automated loading and unloading systems allow truck and container loading and unloading times to be reduced from half an hour to a matter of minutes. Return on investment times are short due to the immediate savings compared to traditional loading and unloading. The applicability of most of these systems is, however, limited.

Most truck and container loading and unloading systems are aimed at shuttle traffic between different facilities of the same company. Conveyor based systems are the most widely spread loading and unloading solutions. Their applicability is, nonetheless, restricted, as they require alterations to the cargo space. Investing in a fleet of modified containers is many times not an option, especially for steel manufacturers, as fleet management becomes impossible when goods are shipped to different customers around the world. Thus, the focus has to be on systems capable of loading standard cargo space.

Another quite widely adopted group of solutions require a special base frame structure beneath the cargo to accommodate the structures of the loading and unloading equipment. Even though standard cargo space is adequate, also this type of solution suffers from the restriction that both the sending and receiving ends must be equipped with compatible systems.

This leaves the alternative of different sliding systems for standard cargo space. The problem is that reliable systems have been hard to find. "It was a disaster", a pleased Actiw client explains a demo session held by another vendor. A delegation from the client had flown to central Europe to see first-hand a solution in action from a local provider. It simply didn't work.

“THE DIFFERENCE TO COMPETITION? LOADPLATE WORKS!”

THE CLIENT SUMMARIZES THE RATIONALE BEHIND CHOOSING ACTIW.

PAYBACK IN 3 MONTHS – WHAT ARE THE BENEFITS?

(This is an illustrative example, but similar benefits and results have been verified in actual, real-life installations.)

Let's take a large, modern steel processing plant as an example. The plant ships out close to 3 000 containers of different steel products each year. In the past, the logistics department was forced to load a significant part of the goods on special containers due to the nature of the products. Furthermore, on-site capacity for container loading was limited, resulting in a major part of goods leaving the site on trucks for off-site containerization.

When introducing LoadPlate at the site, the benefits were immediate. The need for special containers was reduced by 85 %, while the total handling capacity increased by 50 %. The logistics department was able to containerize all shipments on-site with the same resources as before.

These benefits translate into direct cost savings. In this case, the benefits were divided into the following categories:

- Product Damages
- Transport Cost
- Off-site Containerization
- Labor
- Health & Safety

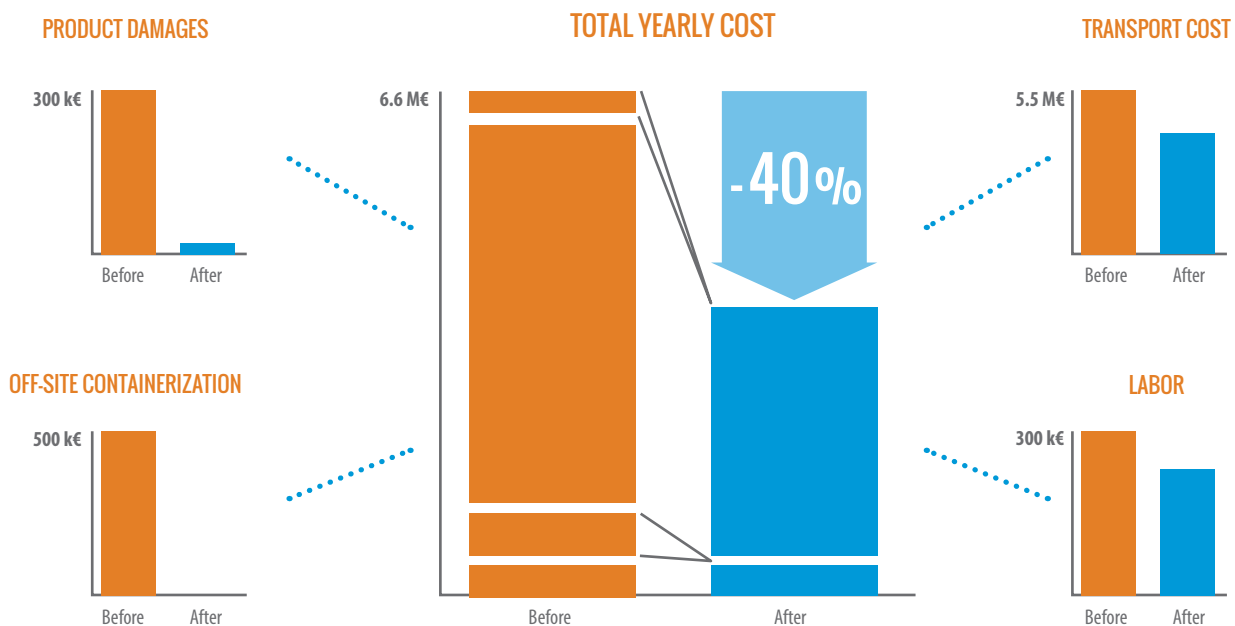

PRODUCT DAMAGES The cost of product damage is largely dependent on the material being handled, it can range from a couple of thousand euros per container in standard steel and up to 100 000 € in special alloys. In this example, let's assume that a load is worth 5 000 € on average. In addition to the damaged goods, costs incur as damages have to be processed, replacement orders sent and receipts archived, requiring collectively at least a day's work.

In a typical situation, with similar volumes, damages occur weekly. With LoadPlate, these damages are almost non-existent. Some occasional mistakes might happen when preparing loads, but only a couple of times a year at maximum. This reduces product damage costs by 95 %, from a 300 000 euro range down to some tens of thousands annually. The difference can be even greater if the loading has been performed by 3rd party stevedores, who generally do not care about the damage and simply shove the cargo into the containers.

TRANSPORT COST Usually, automated loading projects are primarily initiated in order to move from special containers to standard dry containers, due to both availability and expense. The availability of open top containers and flatracks is scarce. Availability issues, at worst, could delay shipments considerably. Special containers are also substantially more expensive than dry containers. Renting open top containers may cost up to double and flatracks close to three times that of a dry container.

The savings in container rents are often the single largest cost benefit of the investment in LoadPlate. In the example, the need of special containers was reduced by 85 %, equaling total cost savings of roughly one third. Container renting summed up to 5,5 M€ before, while after the introduction of the LoadPlate, this figure shrunk to 3,7 M€ range.

OFF-SITE CONTAINERIZATION Often, the capacity for containerization is limited on-site, as in the example, resulting in some of the goods being containerized off-site. Off-site containerization is expensive. First, the goods

must be loaded onto trucks and driven to a harbor or similar hub for containerization. In the example, the cost of transport is assumed to be 200 € per container. Second, the 3rd party operator charges substantial amount of money for the containerization service, say 350 € for filling a container. In the example case, by sending almost thousand containers for off-site containerization each year, the annual cost was around 500 000 €. This cost was eliminated by the LoadPlate.

"There is nothing we couldn't load with the LoadPlate", one of Actiw's LoadPlate customers state.

LABOR Manual loading is usually quite labor intensive, as the loading of one single container requires a crew of several people. With LoadPlate, the operation is much streamlined.

In the example case, the total workforce remained the same, but work could be made in three shifts instead of the earlier two. As a result, the total capacity increased by 50 % and off-site containerization was not required anymore.

Additional benefits were gained, as some of the goods were shipped to another site within the company. When loading with the LoadPlate, using unloading preparations, the unloading can be made simple and efficient as the cargo is pulled out of the container all at once. At the other site, direct labor cost associated with unloading was cut by three quarters. In total, labor cost savings were 22 %.

HEALTH & SAFETY Besides the direct financial benefits, improving safety is one major reason for investing in LoadPlate. Especially open top containers impose safety risks. When the top is removed, somebody must climb a ladder to remove it. Furthermore, in reality, somebody is required to be inside the open top container when loading, to adjust the cargo. When handling large metal elements, weighing several tons, it is not a safe place to be. With LoadPlate, all you have to do is to place the load on the plate with cranes, freely in open space, and push a button.

RETURN OF INVESTMENTS

The investment in a LoadPlate is typically around a couple of hundred thousand euros, depending on the environment where it will be used in. In some cases, it is justified to make some related investments at the same time to further improve the outbound logistics function, for example building a specific indoor area for loading or invest in some additional terminal equipment. In the case example, let's assume a total investment of 500 000 euros, which is a clear overestimation in most cases.

When we combine this information with the efficiency gains explained above, we can model the investment.

When using a WACC (Weighted Average Cost of Capital) of 10 % for discounting future cash flows, the investment has a payback period of mere 3 months. ROIC (Return On Invested Capital) during the first year is 480 % and the ROI (Return On Investment) is an equally staggering 3 145 % when calculated for the first 10 years, although the expected lifetime of LoadPlate is well over 10 years. The NPV (Net Present Value) for the same period results in 15,7 million euros. Not bad for a half a million investment.

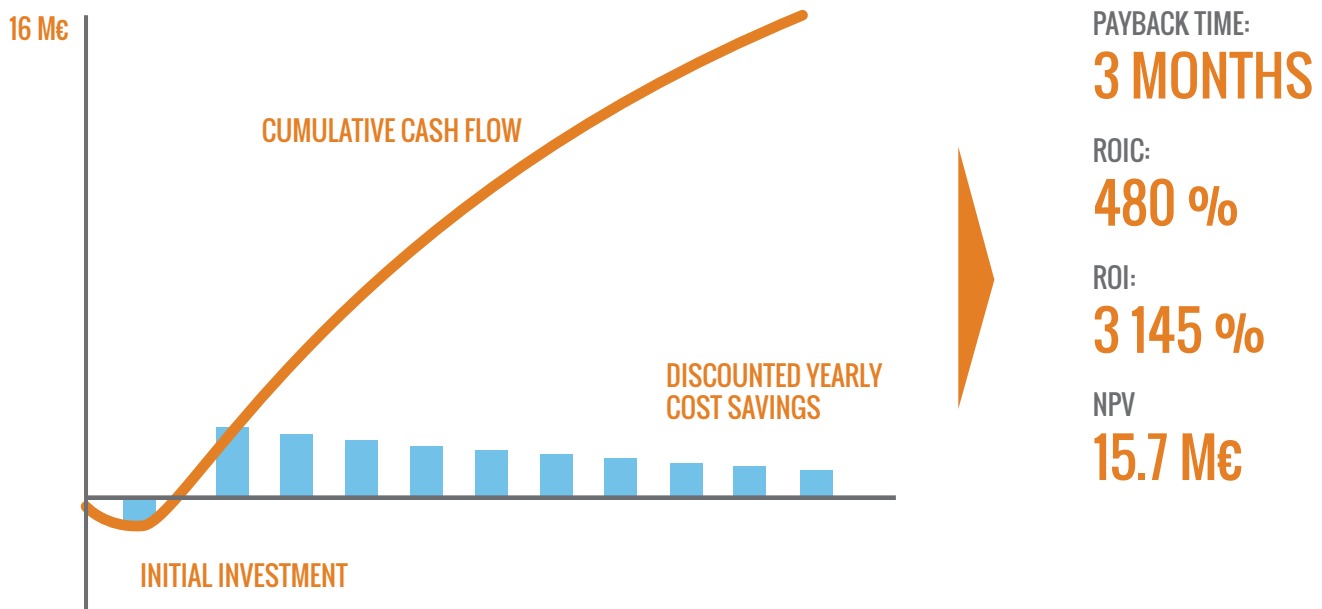

It is evident that the LoadPlate is an amazingly successful investment.

APPLICATIONS FOR THE LOADPLATE – SHOULD I CONSIDER THIS?

This case study demonstrates a situation that steel manufacturers, in general, are facing; moving bulky, heavy items that are poorly suitable for containerization. Actiw LoadPlate has, however, several additional benefits for different applications. Next, some of these are briefly explained:

- **Operational cost savings** – Conventional loading is quite labor intensive, because many times one loading crew consists of 3 persons driving forklifts and preparing a single container or trailer. With LoadPlate, 1 person can operate the LoadPlate and perform the loading faster than traditionally. Additional savings are gained as fewer forklifts are required due to the mechanization of the process.
- **Cargo space utilization** – As demonstrated in this case, the LoadPlate is beneficial when loading long, heavy cargo. The LoadPlate is, however, useful also in situations when volume is the restricting factor. For example, with timber products space utilization can typically be improved from a few even up to 25 % depending on the type of goods and packages.
- **Transportation idling cost** – The idling time of trucks is reduced as the loading and unloading is completed significantly faster than manually. This applies to all types of cargo.
- **Loading dock space savings** – Fewer loading and unloading docks are needed because each dock can handle higher volumes.
- **Cost of ownership and sustainability** - LoadPlate maintenance and spare part costs are significantly lower, when compared to forklift operations, and it is highly energy efficient, reducing CO2 emissions significantly.

Actiw LoadPlate has made automated loading and unloading possible in situations where it was earlier considered impossible. Besides its obvious advantage of being able to load standard cargo spaces without requiring any alterations, the LoadPlate is at least as efficient as any other loading automation system.

**STOP LOSING
MONEY AND
CONTACT THE
EXPERTS AT ACTIW
TO FIND OUT WHAT
KIND OF BUSINESS
IMPACT LOADPLATE
COULD PROVIDE FOR
YOUR BUSINESS!**

ACTIW LOADPLATE®

www.loadplate.com



Actiw Oy is a Finland based manufacturer and systems integrator, specialized in intelligent and sustainable automated warehouse and loading solutions. Actiw has a solid track record with dozens of successful installations and pleased clients; Actiw's automated material handling projects have been executed since mid-1980. The company has invested strongly in developing their own, unique automated storing, sequencing and loading systems for the international market. For more information, please visit: www.loadplate.com | www.actiw.com

Symbioosi Partners Ltd is a Helsinki, Finland, based sales development powerhouse. Symbioosi has prepared this white paper in cooperation with Actiw. For more information, please visit: www.symbioosi.fi



Actiw Oy | Voimapolku 2 | FI-76850 NAARAJÄRVI - FINLAND
Phone +358 (0)207 424 820 | Fax +358 (0)207 424 839 | info@actiw.com
www.loadplate.com | www.actiw.com